

# Straight flight staircase

Part	Part. no.
1 Railing connector	MK1217
2 Angle bracket	VF1001
3 Angle support	LU8024
4 Bannister hook against baluster	LK9011

Part	Part. no.
5 Bannister hook against wall	LK9010
6 L-support	LU0130
7 Front edge	FKxxxx
8 U-profile	UPxxxx

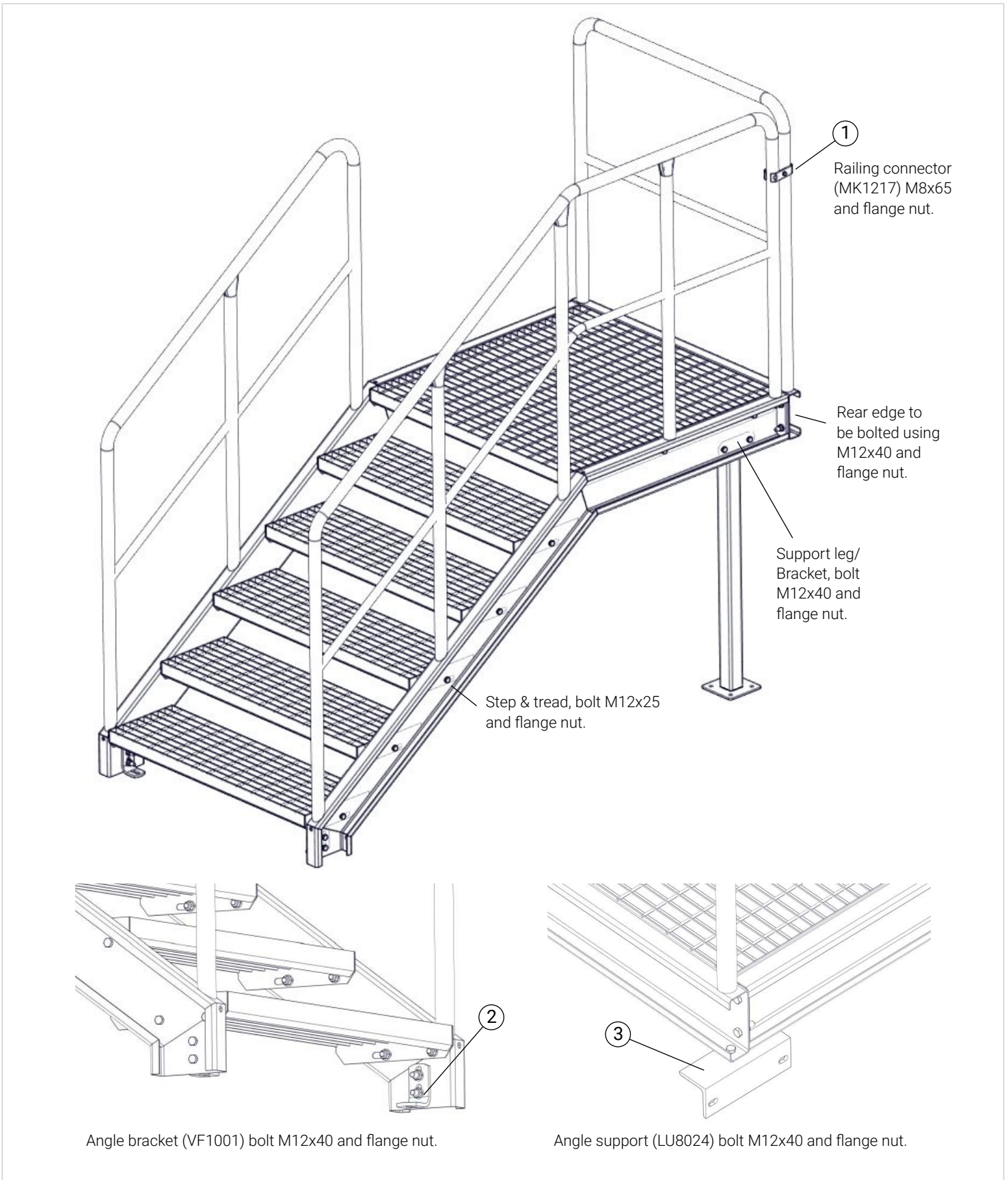

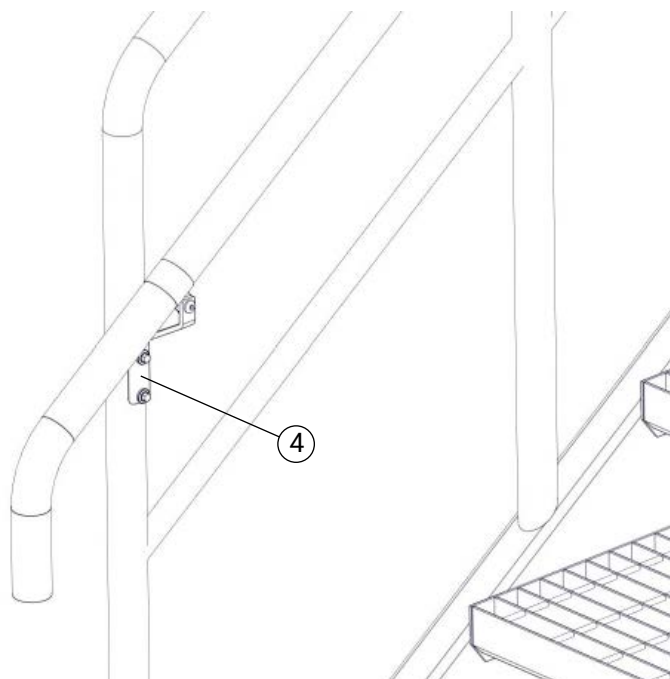

### Extra bannister

Bannister hook (LK9011) to be screwed to riser using self-tapping screw 5.5x22. Handrail clamp located on the inside of the hook to be screwed using stainless steel screw M8x20 and nut.

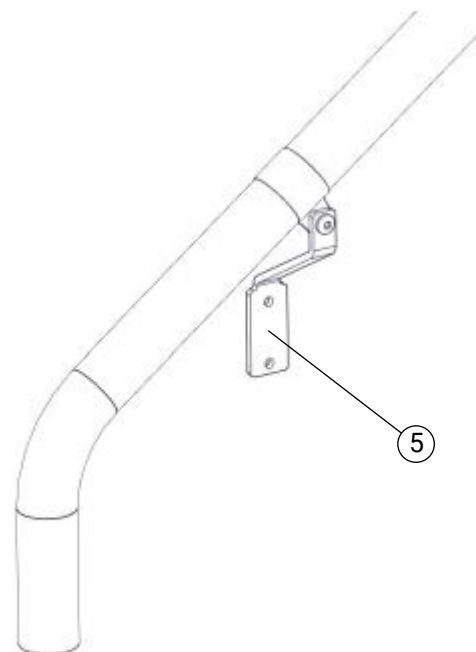

### Banister on wall

Bannister hook (LK9010) screwed to wall, hole in bannister hook  $\varnothing 7$  mm. Handrail clamp located on the inside of the hook to be screwed using stainless steel screw M8x20 and nut.

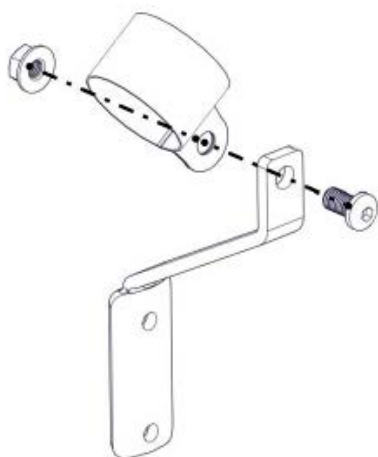

### Tube bannister

Handrail clamp located on the inside of the hook to be screwed using stainless steel screw M8x20 and nut.

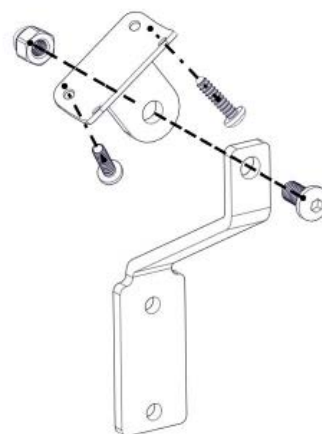

### Wooden bannister

Attachment for wooden handrail located on the inside of the hook to be screwed using stainless steel screw M8x20 and nut. Wooden handrail to be screwed using wood screw 5.5x25 mm.

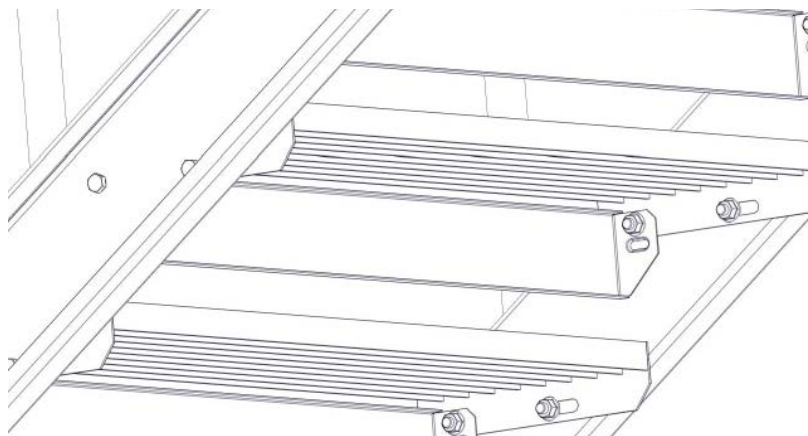

### Riser bar

The riser bar is to be screwed into the front step hole between stair tread ends.

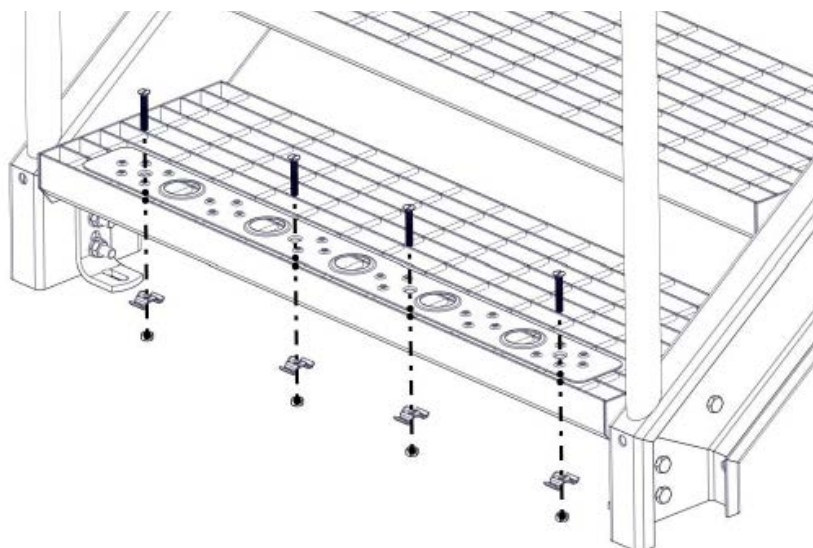

### Contrast marking

Attach contrast marking to plank type flooring steps using countersunk screw M8x50, upper section for grating and nut.

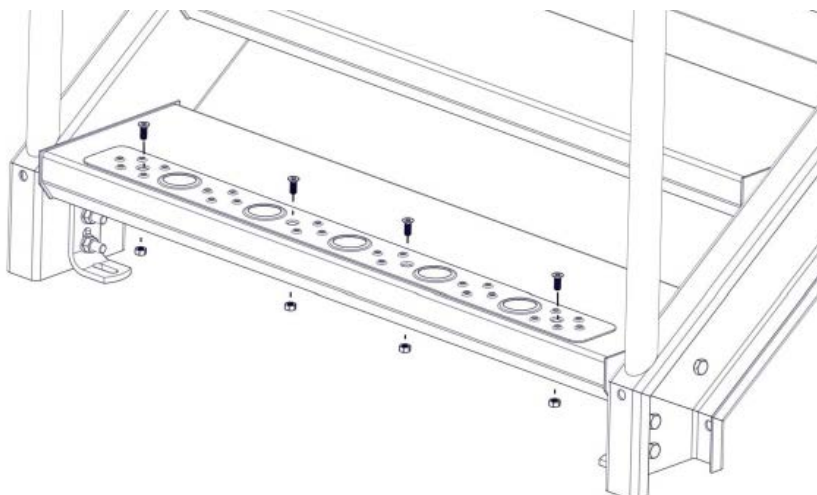

### Contrast marking (durbar plate/plank type flooring)

Attach contrast marking using counter-sunk screw M8x20 and nut, hole in step pilot drilled during installation by a fitter.

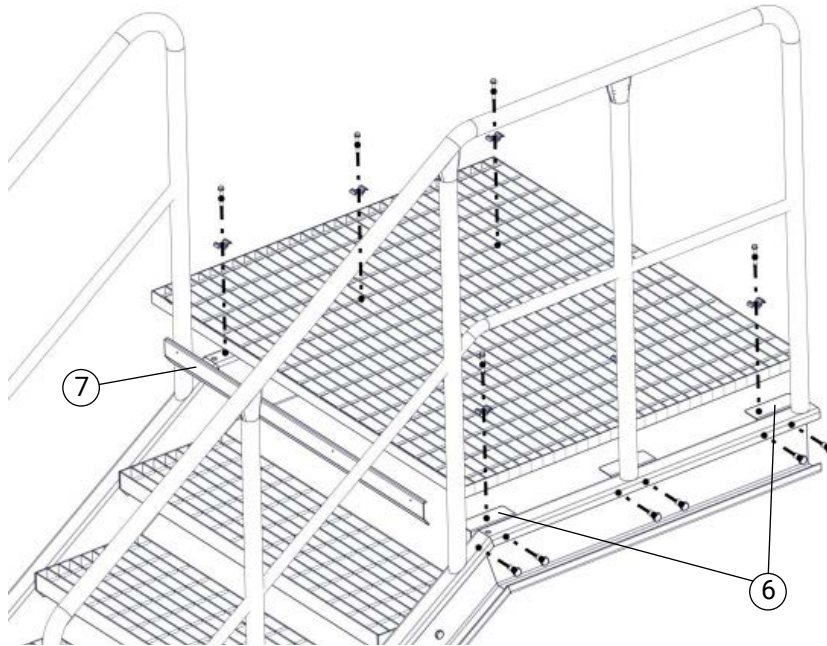

L-support (LU0130) for plank type flooring screwed to side pieces using bolt M12x25 and flange nut. Attach plank type flooring to top side L-support/side pieces using self-tapping screw 6.3x50 mm and top section.

Front edge (FKxxxx) pop riveted (4x9.5 mm) to plank type flooring, hole in carrier steel to be pilot drilled during installation by a fitter.

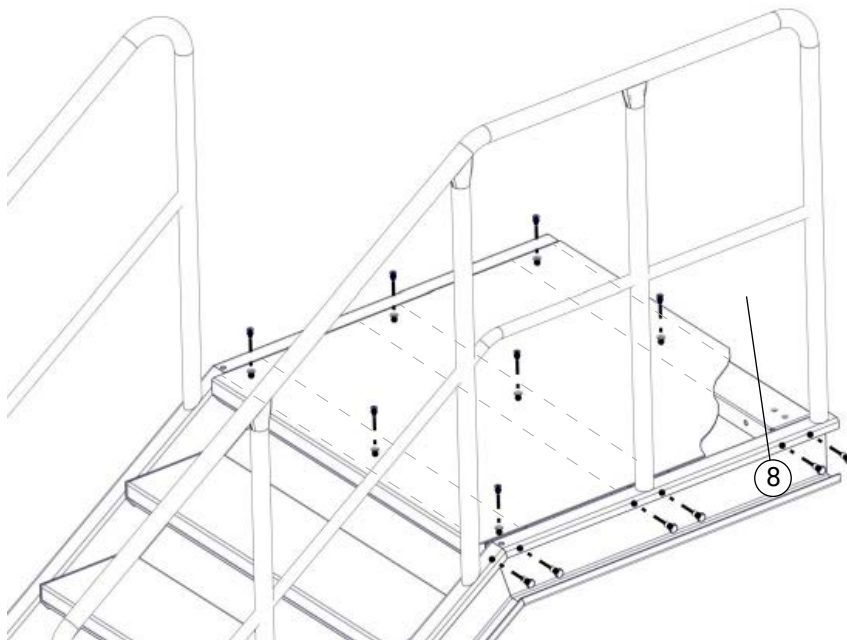

Screw U-profile (UPxxxx) between side pieces using bolt M12x25 and flange nut. Screw durbar plate/ smooth plate floor to U-profiles using countersunk screw M8x20 (U-profile is threaded). Filling may be necessary on sheet metal steps that are to be covered with carpet.